

Hubbell Power Systems, Inc. presents the
CHANCE® Padmounted Air-Insulated Switchgear

AIS - 15kV & 25kV

Provides combination of Deadfront
protection with Air-Insulation benefits



15 & 25 kV

Air-Insulated Deadfront Padmounted Switchgear

Product Description

The AIS padmounted switchgear is an air-insulated, deadfront switching device used for sectionalizing underground distribution systems. It is available in 15kV and 25kV ratings and in a variety of switch/fuse configurations. There are also extensive options available.

The AIS switchgear is a true deadfront design with a sealed switching compartment, utilizing air as the insulating medium along with a deadfront connector system. This combination minimizes electrical exposure to work crews and the public, reduces outages, reduces maintenance requirements and provides the most cost effective solution for 15kV and 25kV underground system sectionalizing.

Product Function

Air-insulated switchgear are loadbreak switches designed to provide a means for disconnecting, sectionalizing and isolating the electrical distribution system effectively and safely.

Features	Benefits
True air-insulated deadfront design	<ul style="list-style-type: none"> Minimizes electrical exposure to work crews and the public Reduces maintenance requirements Reduces outages caused by vegetation and/or animal intrusion
Louvered Enclosure Design	Prevents unwanted gases and moisture from building up inside the enclosure
11-Gauge mild steel	Superior strength and durability (304-Stainless Steel optional)
Large viewing windows	Maximum visibility of 600A switch position and fuse condition
Built-in 9" base spacing	Increases door clearance and reduces the need for additional base spacers
No center door support	Increases working area in cable compartments
Replaceable switch-way bushings	All switch-way bushings (200A or 600A) are easily field replaceable
Internal no-drip compound	Prevents moisture condensation from accumulating under the roof
Fault indicator window	Viewing window for mounting common fault indicators

AIS Design Features:

Switch Compartment:

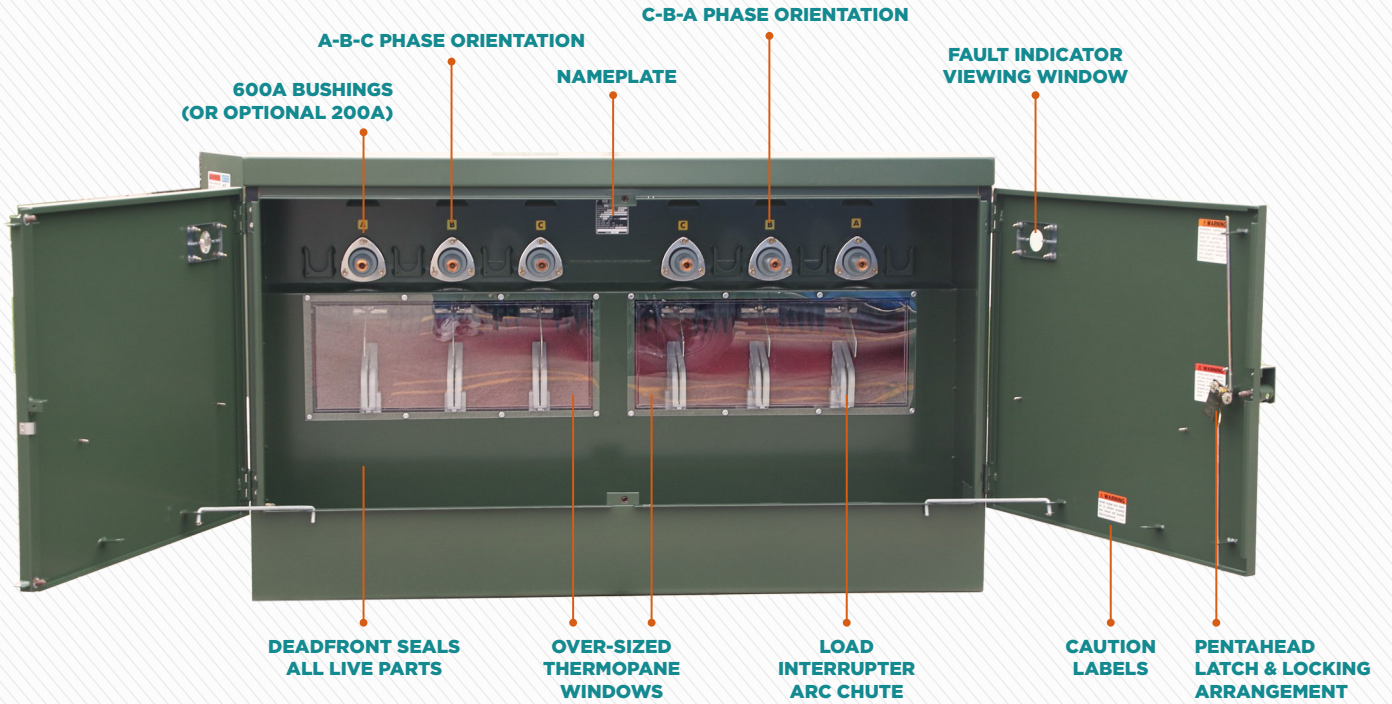

Fuse Compartment:

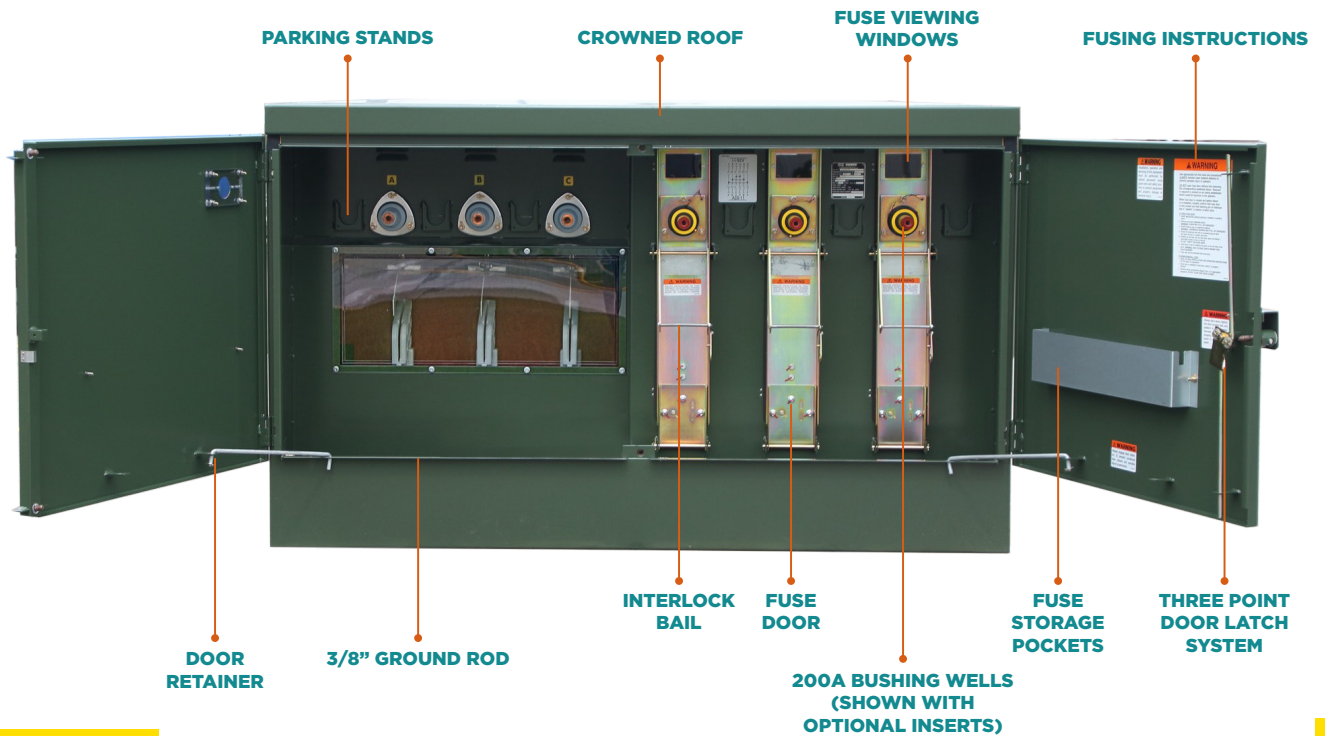

AIS Design Features in Depth

Structural Stability

The fully welded enclosure is constructed of heavy gauge steel for superior strength and durability. For applications in highly corrosive areas, stainless steel enclosures are available.

Exterior Protection

The surface of each enclosure undergoes a multistage chemical cleaning process. A powder coat finish is then applied for superior corrosion protection, durability and ultraviolet protection. This coating system meets the latest revision of ANSI/IEEE Standard C57.12.28, "Padmounted Equipment Enclosure Integrity."

Padmount Interchangeability

The AIS is designed to be pad interchangeable with competitive designs. Base adapters also are available to make the AIS compatible with pads for some live front gear.

Externally Replaceable Bushings

The 600A bushings on the AIS switch are truly externally replaceable. This feature allows the utility to quickly replace any bushings in the field without disassembling the face-plate. Due to the individualized sub-assembly design, the AIS may be provided with 200A bushing wells in lieu of 600A bushings.

External Side Operator & Removable Lifting Plate

An external operating mechanism is housed on the outside of the center compartment and allows linemen to perform switching functions without opening the cable compartment. Each three-phase gang switch is equipped with its own operator. The external operator can be padlocked in either the open or closed position.



A sturdy operating handle is stored in each operator compartment. The padlocking provisions on the compartment doors accommodate the majority of available padlocks.

Door Latching System

The low-profile door latch assembly has no protruding handles. The pentahead on the right operates the three-point latch. The pentahead on the left secures the door to the center door jamb. Both pentaheads must be engaged before a padlock can be installed.



Visible Break

Oversized Thermopane windows provide excellent viewing for verification of visible break. The large windows are constructed of heavy-duty, mar-proof double pane polycarbonate. They are easily removed in the shop to provide ready access to switch components.



Confirming the visible break through the AIS windows eliminates the need to move the 600A connectors. Sufficient space is provided for feed-through bushings for parking of elbows on parking stands.

Fault Indicator Window & Louvers

The standard fault indicator window allows for visual inspection of the equipment prior to opening up the compartment doors. Also offered as a standard, the louvers feature prevents moisture build up inside the enclosure.



Fusing Flexibility

Fuse versatility was a key design parameter of the AIS in order to utilize existing fuses already approved and in use by the utility and/or to improve coordination with existing fuse systems. A utility using livefront gear can use the same fuses and end fittings in the AIS. The following 3 fuse options are available.

- S&C SMU-20 power fuse
- S&C SM-4Z power fuse
- Cooper type NX current limiting fuse

Indicator windows are provided for locating blown fuses. Fuse doors are mechanically inter-changeable and require only a simple operation, without de-energizing the 600 amp line side, to change in the field from one type fuse to another.



Loadbreak elbow must be removed before the mechanical latch can be opened. Parking the elbow insures that the load is safely disconnected. After the elbow has been parked, the interlock bail on the fuse door is released. As fuse door is lowered, a spring-activated barrier closes behind it to maintain the deadfront integrity of the switch's tap side. When the fuse door is fully opened, the fuse tray is positioned an ample distance from the cables for easy removal of the fuses.

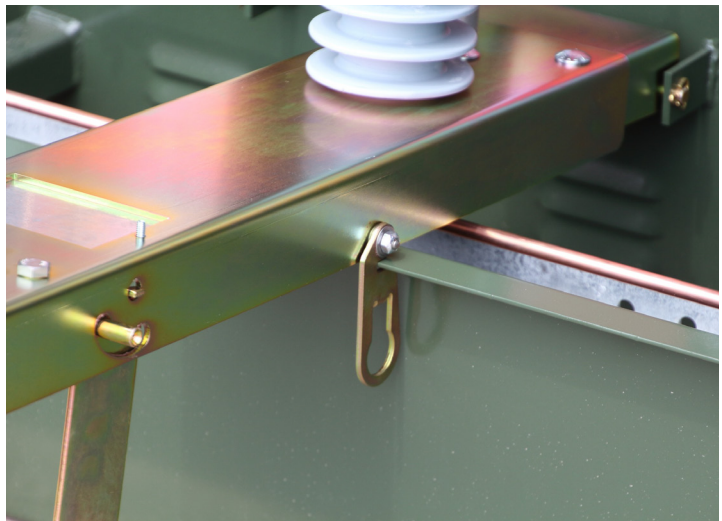

Fuse door latching provision to change fuses with a grip-all stick as to not cause movement of the fuse door while open.

Models









The Padmounted Air-Insulated Switchgear (AIS) comes in several standard models to meet differing distribution switching requirements. Each model is available in either 15kV or 25kV ratings. All configurations and ratings are factory selected and can not be field configured. Model configurations are available in combinations of ways (single- or three-phase) which may be switched, fused or tapped (solid) , with available fusing options. Fusing options for S&C Electric Company are the SM-20 and SM-4Z, and fusing option for Cooper is the Cooper NX. Additional fusing is field configurable via fuse door change-outs (S&C Electric Company SM-20 and SM-4Z, and Cooper NX). Consult factory representative for details.

AIS Ratings | Table 1-1

Nominal Voltage	15kV	25kV
Maximum Design Voltage	15.5kV	29kV
BIL	95kV	125kV
One-Minute Withstand (60Hz)		
Switch and Terminators	35kV	60kV
Continuous Current Rating		
Switch Side	600 Amp	600 Amp
Fuse Side (Maximum)	200 Amp	200 Amp
Load Switching	600 Amp	600 Amp
Cable Charging Current	10 Amp	15 Amp
Magnetizing Current	21 Amp	21 Amp
Momentary and Making Current*	12,000 Amps, rms, symm 19,200 Amps, rms, asymm	12,000 Amps, rms, symm 19,200 Amps, rms, asymm

*Consult factory for other requirements.

Ordering Information: 15 and 25 kV AIS Padmounted Sectionalizing Equipment | Table 1-2

Switch Configuration	One-Line Diagram	Voltage kV		Termination & Bus Ratings – Amps				Phases
		Nom.	BIL	Line 1	Line 2	Line 3	Line 4	
AIS-1A		15/25	95/125	200	200	200	—	1
AIS-3		15/25	95/125	600*	600*	—	—	3
AIS-5		15/25	95/125	600*	200	—	—	3
AIS-6		15/25	95/125	600*	600*	—	200	3
AIS-9		15/25	95/125	600*	600*	200	200	3
AIS-10		15/25	95/125	600*	600*	600*	600*	3
AIS-11		15/25	95/125	600*	600*	600*	200	3
AIS-12		15/25	95/125	200	600*	200	200	3
AIS-13A		15/25	95/125	600*	600*	600*	—	3

*200A universal bushing wells can be supplied instead of 600A deadbreak bushings.

AIS Ratings | Table 1-3

Model No.	Height	Width	Depth		Nominal
	In (cm)	In (cm)	Base	Overall	lbs. (kg)
			In (cm)	In (cm)	
AIS-1A/15kV	45 (114)	41 (104)	36-7/8 (94)	38-1/4 (97)	475 (215)
AIS-1A/25kV	51-1/2 (131)	46-1/2 (118)	49-3/4 (126)	51-1/8 (130)	695 (315)
AIS-3/15kV	45 (114)	41 (104)	64-1/2 (164)	67-1/4 (171)	875 (395)
AIS-3/25kV	46-1/2 (118)	46-1/2 (118)	79-1/2 (202)	82-1/4 (209)	1275 (580)
AIS-5/15kV	45 (114)	41 (104)	64-1/2 (164)	67-1/4 (171)	900 (410)
AIS-5/25kV	51-1/2 (131)	46-1/2 (118)	79-1/2 (202)	82-1/4 (209)	1350 (610)
AIS-6/15kV	45 (114)	75 (190)	64-1/2 (164)	67-1/4 (171)	1450 (660)
AIS-6/25kV	51-1/2 (131)	84 (213)	79-1/2 (202)	82-1/4 (209)	1950 (885)
AIS-9/15kV	45 (114)	75 (190)	64-1/2 (164)	67-1/4 (171)	1500 (680)
AIS-9/25kV	51-1/2 (131)	84 (213)	79-1/2 (202)	82-1/4 (209)	2000 (910)
AIS-10/15kV	45 (114)	75 (190)	70-1/2 (179)	71-1/4 (186)	1650 (750)
AIS-10/25kV	46-1/2 (118)	84 (213)	86 (220)	88-3/4 (225)	2000 (910)
AIS-11/15kV	45 (114)	75 (190)	70-1/2 (179)	71-1/4 (186)	1650 (750)
AIS-11/25kV	51-1/2 (131)	84 (213)	86 (220)	88-3/4 (225)	2200 (1000)
AIS-12/15kV	45 (114)	75 (190)	64-1/2 (164)	67-1/4 (171)	1550 (705)
AIS-12/25kV	51-1/2 (131)	84 (213)	79-1/2 (202)	82-1/4 (209)	2075 (940)
AIS-13A/15kV	45 (114)	75 (190)	70-1/2 (179)	71-1/4 (186)	1600 (725)
AIS-13A/25kV	46-1/2 (118)	84 (213)	86 (220)	88-3/4 (225)	1950 (885)

Production Testing

After assembly, all switches are tested to ANSI Standards:

1. Voltage Drop Test (IR). Each line direction of the switch configuration is tested. The IR test is a current test where the voltage drop across the area tested is measured to indicate the impedance in the circuit which is tested. This test assures reliable electrical connections.
2. High Potential Testing. Each switch is tested phase-to-phase and phase-to-ground across the insulation system with the switch in the open and closed positions.

AIS Switch Catalog Number System

BASIC FORMAT = X X X X X X X X X X X
POSITION = 1 2 3 4 5 6 7 8 9 10 11

Example Part Number

Part # A090A20C1EIL, shown right below, is for an AIS 9 model which is 15kV unit with provisions for SM-20 fuses, 600A source bushings, removable 600A bushing studs, 6" pad adapter, bushing inserts, and Kirk Key interlocks to prevent paralleling source side switches and prevent entry to fuse doors without all feed switches locked open.

POSITION 8-11	
OPTIONS	
C1	Removable stud 600A bushings
D1	Automatic door latch (standard with stainless steel, option F)
E	6" base adapter to allow mounting AIS switch on the pad of a different manufacturer's switch of the same configuration (contact factory for specific details and availability)
F	Stainless steel enclosure
G	Kirk Key Interlocks to prevent paralleling source side switches
H	Kirk Key interlocks to prevent entry to fuse doors without all feed switches locked open.
I	200A bushing well inserts
L	Kirk Key Interlocks combining options G and H
Q	6" base spacer
U	12" base spacer
V	18" base spacer
W	24" base spacer



POSITION 1	
kV RATING	
A	15kV
B	25kV

POSITION 2-4	
SWITCH CONFIGURATION	
01A	AIS-1A
030	AIS-3
050	AIS-5
060	AIS-6
090	AIS-9
100	AIS-10
110	AIS-11
120	AIS-12
13A	AIS-13A

POSITION 5	
SOURCE CONNECTOR PROVISIONS	
A	600A deadbreak bushings
B	200A universal bushing wells
NOTE: All fuse connector provisions are supplied with 200A universal bushing well inserts must be specified as an option.	

00 = No fusing (i.e. AIS3, AIS-10, AIS-13A)

POSITION 6-7					
For 15 kV AIS : Select the appropriate fuse from table below:					
Fuse Manufacturer	Fuse Mounting	Fuse Mounting	Ratings		Catalog Number Additions
			Maximum Design kV	Maximum Amperes RMS	
S&C®	SM-20	NONE	17	200	20
S&C®	SM-20	SML20	17	200	2H
S&C®	SM-4Z	NONE	17	200	4Z
S&C®	SM-4Z	SM4Z	17	200	4H
Cooper®	NX	NX	8.3	1.5-40	N1
Cooper®	NX	NX	8.3 15.5	50-100 1.5-40	N2
Cooper®	NX	NX	15.5	50-100	N3

POSITION 6-7					
For 25 kV AIS : Select the appropriate fuse from table below:					
Fuse Manufacturer	Fuse Mounting	Fuse Mounting	Ratings		Catalog Number Additions
			Maximum Design kV	Maximum Amperes RMS	
S&C®	SM-20	NONE	27	200	20
S&C®	SM-20	SML20	27	200	2H
S&C®	SM-4Z	NONE	27	200	4Z
S&C®	SM-4Z	SM4Z	27	200	4H
Cooper®	NX	NX	15.5	1.5-40	N1
Cooper®	NX	NX	15.5 23	50-100 6-40	N2
Cooper®	NX	NX	23	6-50	N3

